

AUMARK

IT'S ALL GOOD



FOTON COMMERCIAL VEHICLES AUSTRALIA



FOTON

FOTON

Beiqi Foton Motors LLC is a state-owned, publicly-traded automotive manufacturer. It is the number one Commercial Vehicle Manufacturer in China and has been for the last 8 years. It ranks as the number two Commercial Vehicle Manufacturer in the world. Last year they produced over 600,000 vehicles and exported over 10% of those vehicles to Europe and Africa. At present, it has over 28,000 employees and world class capability in research and development. They are certified to ISO 9001:2000 with R&D offices in Germany, Japan and Taiwan and manufacturing facilities thru out Asia. We are proud that Foton has selected Western Star Trucks Australia to distribute their line of Commercial Vehicles in Australia.



Aumark

The Aumark is a state-of-the art light commercial vehicle designed from the ground up to deliver outstanding value in its class. With its large roomy cabin and large glass areas for outstanding visibility it is designed to make your company more productive and your drivers more comfortable all with the ease of being driven using an ordinary car license. It comes standard with an all steel utility tray allowing it to start earning you money from the first turn of the wheel.

THE VEHICLE

Cummins ISF Engine

When it comes to heavy duty diesel engines no one does it better than Cummins. The ISF is the latest addition to Cummins' extensive range of dependable engines. Based on Cummins' experience with over 4 million engines in use in on-highway applications around the world, the ISF family has been developed with high performance and low weight, specifically for light commercial applications. The engine has been designed to comply with the tough ADR 80/02 emission standards and its modular design enables the move to the even tougher requirements of ADR 80/03 with minimal impact on the installation. The new four cylinder, 2.8L common rail turbocharged and intercooled diesel engine comes standard in the Aumark with a rating of 110 kw @ 3400 rpm and 360 Nm of net torque at 1800 rpm. The ISF engine achieves emission compliance using Selective Catalytic Reduction (SCR).

Why SCR

SCR technology is the most cost-effective method to reduce NOx emissions and reduce our environmental impact. SCR is proven technology with over 600,000 trucks operating in Europe on SCR. It is the only technology that optimizes fuel efficiency while allowing the engine to run cleaner. SCR works by injecting a very precise amount of an automotive grade urea/water solution (called Diesel Exhaust Fluid or DEF – it is also known by the trade name AdBlue) into the vehicle's hot exhaust stream. SCR has become the global standard for meeting the most stringent diesel engine emission requirements. DEF usage will be around 2-3% of diesel usage for most operators. A typical Aumark 4.5T vehicle will use about 3-4L of SCR fluid per week.

Power &
Performance



Travel in
Style

Cab Comfort and Features

The Aumark series will provide you with more room to move, in car comfort as well as convenience and style to match. The cab is equipped with air conditioning, am/fm stereo radio with CD player, generous personal storage where you need it, power windows, tilt and telescoping steering wheel, comfortable fully adjustable seating with ample leg room and fold down workstation with handy cup holders.



Specifications

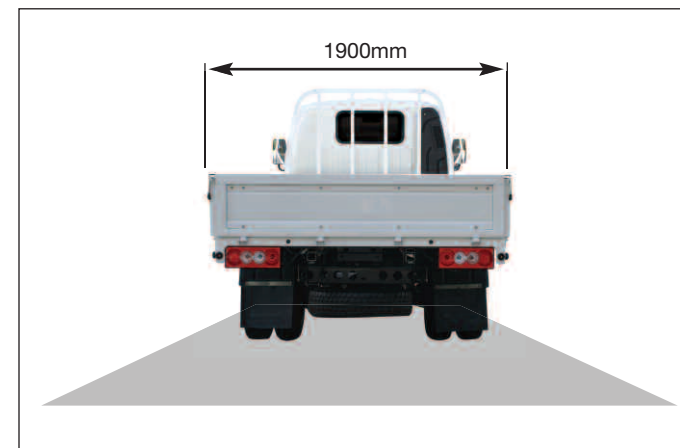
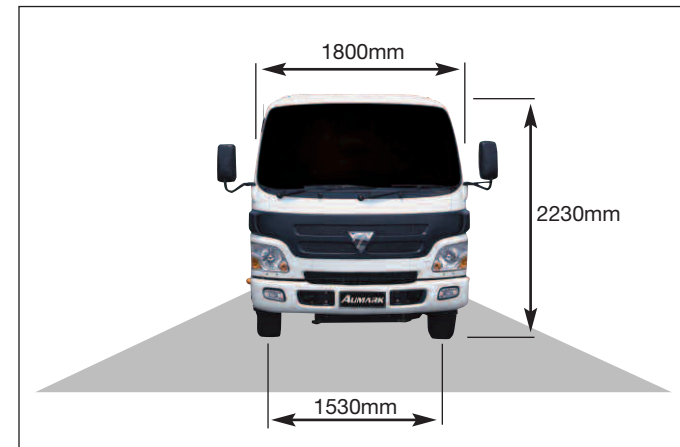
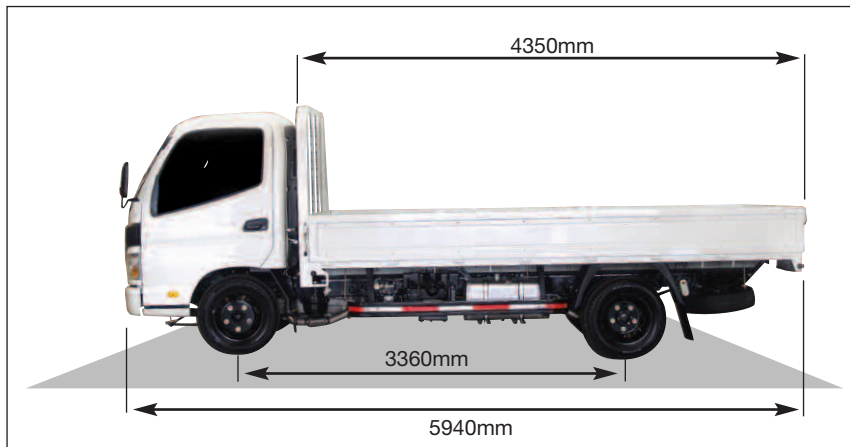

Warranty

Warranty

The Aumark comes standard with a 3yr 100,000km warranty – whichever comes first subject to the terms and conditions detailed in the warranty leaflet.

FOTON COMMERCIAL VEHICLES AUSTRALIA

72 Formation Street, Wacol, Qld 4076 • PO Box 301, Goodna, QLD 4300
Telephone: 07 3271 7777 • Facsimile: 07 3271 2047 • fotontrucks.com.au

